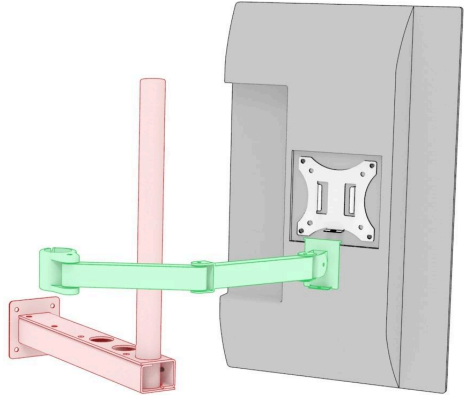
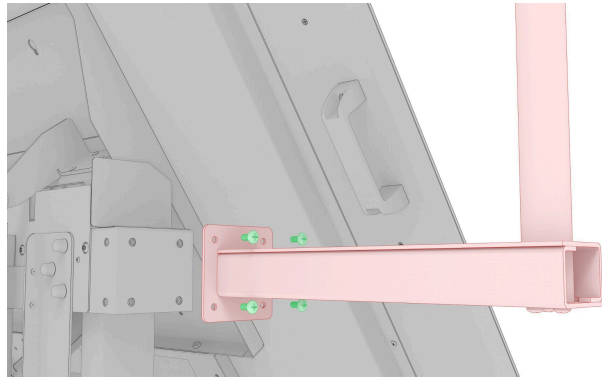

Plan Review Table - Side Monitor Assembly Instructions

Note: The following relates to an accessory for the Volanti Plan Review Table and is to be used together with the Plan Review Table Unpacking and Assembly Instructions.

<p>The Volanti Plan Review Table supports additional monitors on either side of the main display. The standard side monitor accessory option is a 24" Full-HD monitor.</p>	
<p>The side monitor accessory is delivered as a three-part assembly:</p> <ol style="list-style-type: none"> 1. The monitor, we pre-install a mounting bracket on the back of the monitor. 2. An arm that connects to the table with a short vertical pole. 3. An adjustable arm that clamps on the pole at one end, and the monitor clamps on at the other end. 	
<p>The screws, M6 Philips type, for fixing the arm to the table are already fitted to the table. Remove them from the table on the side you would like to fit the monitor then use them to secure the arm to the table as shown here.</p>	

When fitted, you will also need to connect power using the power supply provided and the HDMI video cable, also provided.

Support for the side monitor in addition to the main display is a function of connection to a PC and a Microsoft Windows setting.

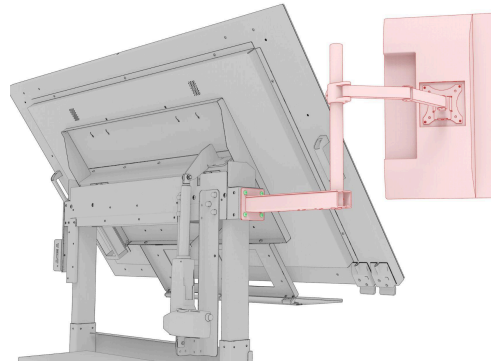

Wiring Note: The side monitor should have the following cables connected:

- HDMI video
- Power

In Microsoft Windows, settings for a secondary monitor are:

To set up a secondary monitor in Windows 11 Pro, follow these steps:

1. Connect the secondary monitor to your computer using the appropriate cable (e.g., HDMI, DisplayPort, VGA, or DVI).
2. Power on the secondary monitor.
3. Windows should automatically detect and configure the secondary monitor. If it doesn't, right-click on the desktop of the main active display and select "Display settings."
4. In the Display settings window, you'll see a representation of both monitors. Click on the secondary monitor (usually labeled as "2").
5. Scroll down to the "Multiple displays" section and click on the dropdown menu. Select "Extend desktop to this display" to use the secondary monitor as an extension of your primary monitor.
6. If needed, you can adjust the resolution, orientation, and scale of the secondary monitor in the Display settings window.
7. You can also rearrange the monitor positions by clicking and dragging the monitor icons at the top of the Display settings window to match their physical arrangement on your desk.
8. Click "Apply" to save the changes.
9. Your secondary monitor should now be set up and ready to use. You can move windows and applications between the monitors by dragging them to the edge of the screen in the direction of the secondary monitor.